

6 Watt Boost LED Driver



FEATURES

- Switch Current Limit 750mA
- Drives High Voltage LED strings (38V)
- Up to 94% Efficiency
- Low Quiescent Ground Current 0.6mA
- 1MHz Fixed Frequency Low noise Operation
- Soft start “in-rush” current limiting
- Shutdown current less than 1µA
- Open LED Overvoltage Protection
- Automatic Shutdown at 1.9V (UVLO)
- Thermal overload protection
- Thin SOT23 5-Lead (1mm max height)

APPLICATIONS

- GPS Navigation Systems
- Portable Media Players
- Handheld Devices, Digital Cameras

ORDERING INFORMATION

| Part Number | Package | Quantity per Reel | Package Marking |
|---------------|-----------------|-------------------|-----------------|
| CAT4240TD-GT3 | TSOT23-5 Green* | 3000 | TG |

* NiPdAu Plated Finish

For Ordering Information details, see page 13.

Pin Configuration

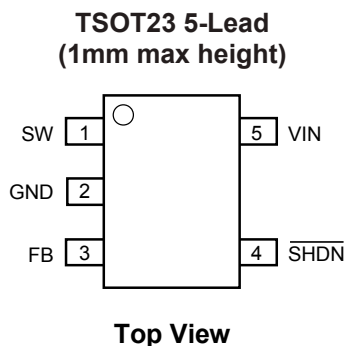

DESCRIPTION

The CAT4240 is a DC/DC step-up converter that delivers an accurate constant current ideal for driving LEDs. Operation at a fixed switching frequency of 1MHz allows the device to be used with small value external ceramic capacitors and inductor. LEDs connected in series are driven with a regulated current set by the external resistor R1. The CAT4240 high-voltage output stage is perfect for driving mid-size and large panel displays containing up to ten white LEDs in series.

LED dimming can be done by using a DC voltage, a logic signal, or a pulse width modulation (PWM) signal. The shutdown input pin allows the device to be placed in power-down mode with “zero” quiescent current.

In addition to thermal protection and overload current limiting, the device also enters a very low power operating mode during “Open LED” fault conditions. The device is housed in a low profile (1mm max height) 5-lead thin SOT23 package for space critical applications.

Typical Application Circuit

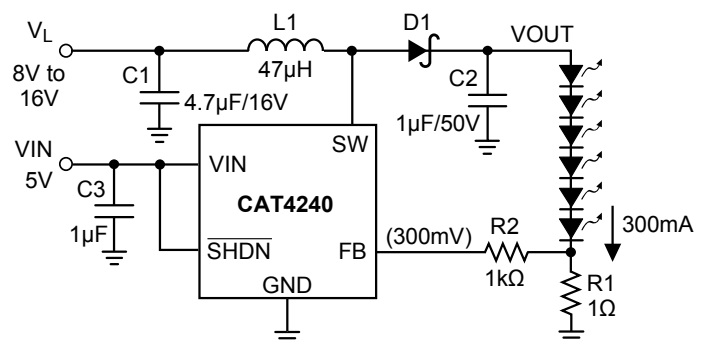

L1: Sumida CDRH6D28-470
D1: Central CMSH1-40 (rated 40V)

ABSOLUTE MAXIMUM RATINGS

| Parameters | Ratings | Units |
|----------------------------------|-------------|-------|
| V _{IN} , FB voltage | -0.3 to +7 | V |
| $\overline{\text{SHDN}}$ voltage | -0.3 to +7 | V |
| SW voltage | -0.3 to 60 | V |
| Storage Temperature Range | -65 to +160 | °C |
| Junction Temperature Range | -40 to +150 | °C |
| Lead Temperature | 300 | °C |

RECOMMENDED OPERATING CONDITIONS

Typical application circuit with external components are shown on page 1.

| Parameters | Range | Units |
|--|------------|-------|
| V _{IN} | up to 5.5 | V |
| SW pin voltage | 0 to 38 | V |
| Ambient Temperature Range ⁽¹⁾ | -40 to +85 | °C |

DC ELECTRICAL CHARACTERISTICS

V_{IN} = 3.6V, ambient temperature of 25°C (over recommended operating conditions unless specified otherwise).

| Symbol | Parameter | Test Conditions | Min | Typ | Max | Units |
|------------------------------------|---|--|------------|------------|------------|--------|
| I _Q | Operating Current | V _{FB} = 0.2V V _{FB} = 0.4V (not switching) | | 0.6 0.1 | 1.5 0.6 | mA |
| I _{SD} | Shutdown Current | V _{SHDN} = 0V | | 0.1 | 1 | µA |
| V _{FB} | FB Pin Voltage | 6 LEDs with I _{LED} = 75mA | 285 | 300 | 315 | mV |
| I _{FB} | FB pin input leakage | | | | 1 | µA |
| I _{LED} | Programmed LED Current | R1 = 10Ω R1 = 5Ω | 28.5 | 30 60 | 31.5 | mA |
| V _{IH} V _{IL} | $\overline{\text{SHDN}}$ Logic High $\overline{\text{SHDN}}$ Logic Low | Enable Threshold Level Shutdown Threshold Level | 0.4 | 0.8 0.7 | 1.5 | V V |
| F _{SW} | Switching Frequency | | 0.8 | 1.0 | 1.3 | MHz |
| DC | Maximum Duty Cycle | V _{IN} = 3V | | 92 | | % |
| I _{LIM} | Switch Current Limit | V _{IN} = 3.6V V _{IN} = 5V | 600 750 | | | mA |
| R _{SW} | Switch “On” Resistance | I _{SW} = 100mA | | 1.0 | 2.0 | Ω |
| I _{LEAK} | Switch Leakage Current | Switch Off, V _{SW} = 30V | | 2 | 5 | µA |
| | Thermal Shutdown | | | 150 | | °C |
| | Thermal Hysteresis | | | 20 | | °C |
| V _{UVLO} | Undervoltage Lockout (UVLO) Threshold | | | 1.9 | | V |
| V _{OV-SW} | Overvoltage Detection Threshold | | | 40 | | V |
| V _{OCL} | Output Voltage Clamp | “Open LED” | | 42 | | V |

Note:

(1) Thin SOT23-5 package thermal resistance θ_{JA} = 135°C/W when mounted on board over a ground plane.

TYPICAL CHARACTERISTICS

VIN = 5V, VL = 13V, TAMB = 25°C, typical application circuit unless otherwise specified.

Quiescent Current vs. VIN (Not Switching)

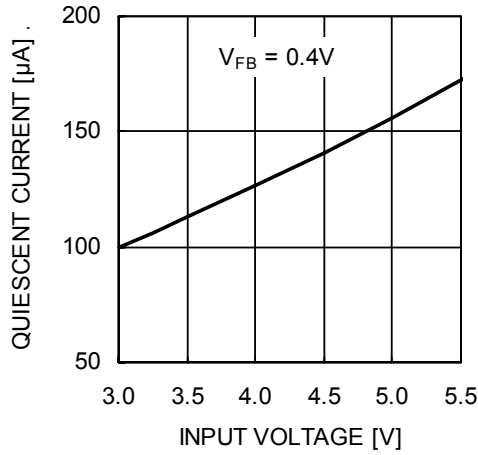

Quiescent Current vs. VIN (Switching)

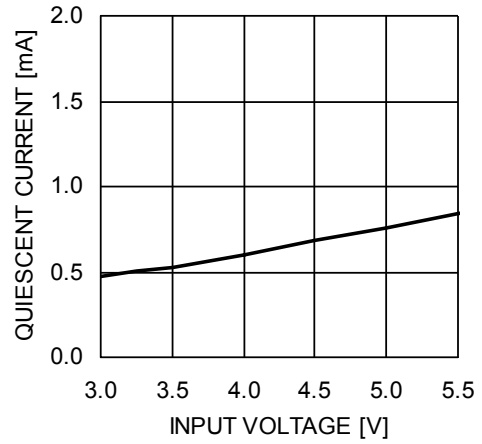

FB pin voltage vs. Temperature

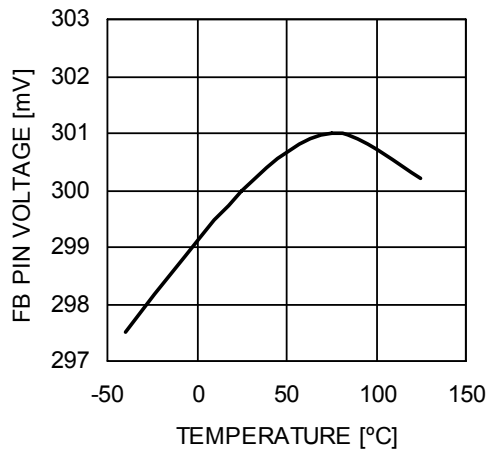

FB Pin Voltage vs. Output Current

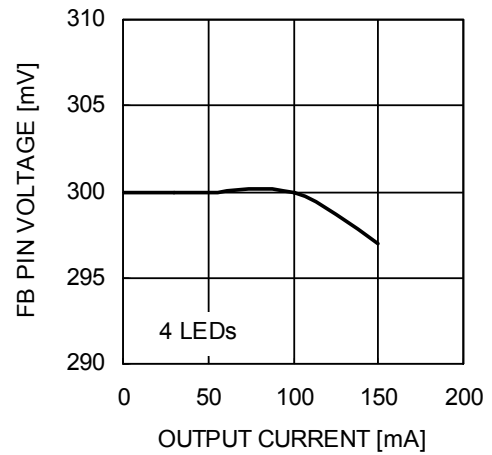

Switching Frequency vs. Supply Voltage

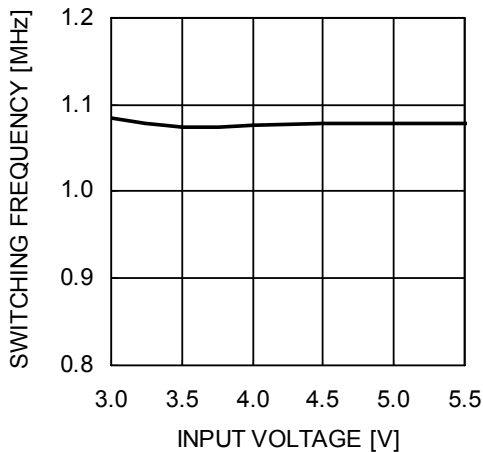

Switch ON Resistance vs. Input Voltage

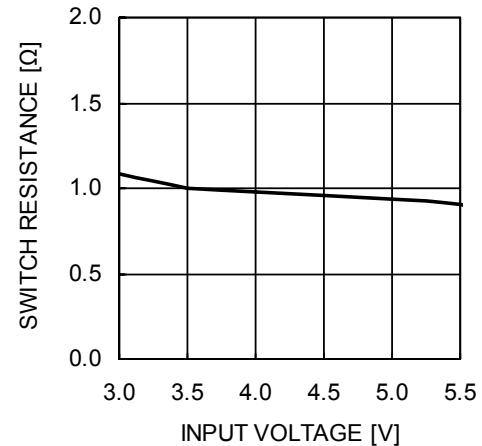

TYPICAL CHARACTERISTICS

VIN = 5V, VL = 13V, TAMB = 25°C, typical application circuit unless otherwise specified.

LED Current vs. Input Voltage

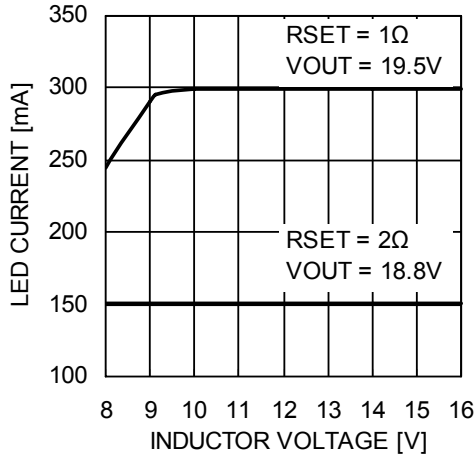

LED Current Regulation

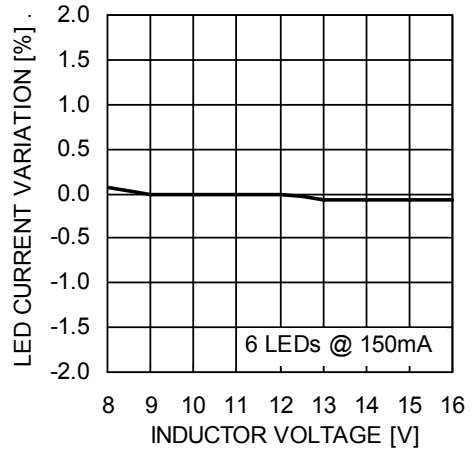

Efficiency vs. Load Current (6 LEDs)

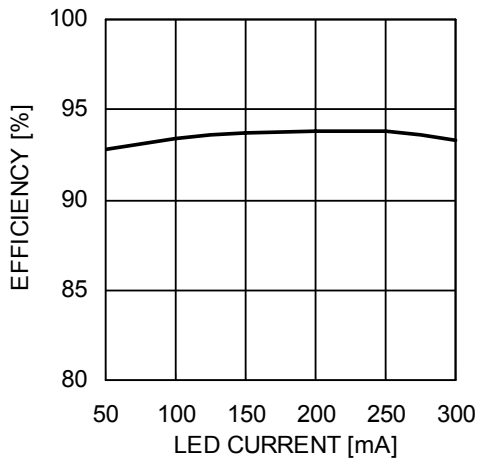

Efficiency vs. Inductor Voltage (6 LEDs)

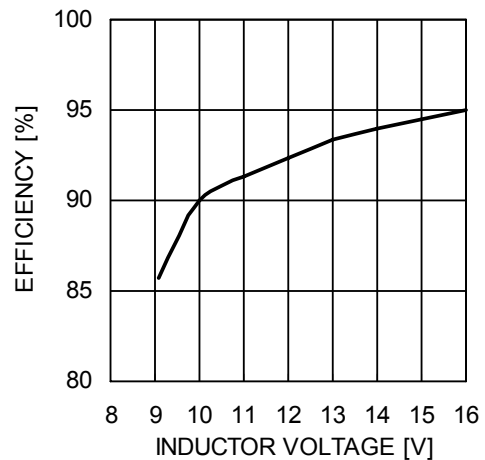

Power-up with 6 LEDs at 300mA

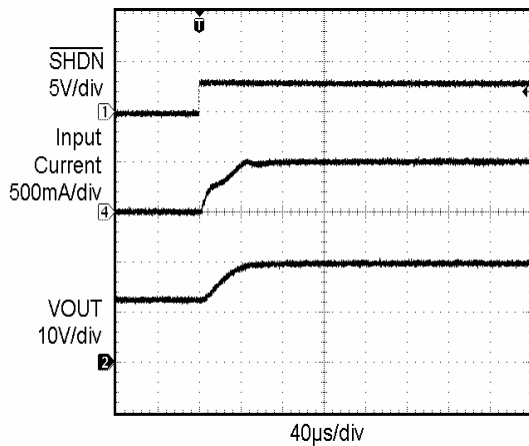

Switching Waveform

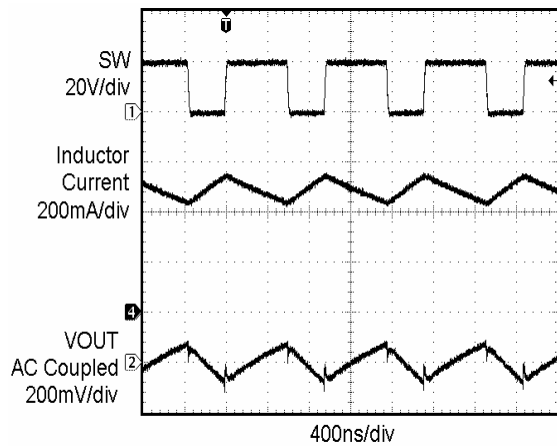

TYPICAL CHARACTERISTICS

V_{IN} = 5V, V_L = 13V, T_{AMB} = 25°C, typical application circuit unless otherwise specified.

Maximum Output Current

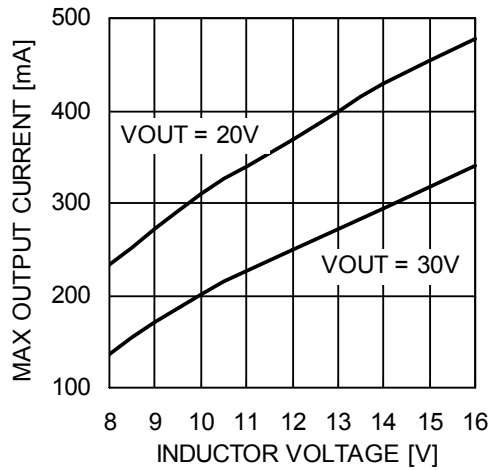

Shutdown Voltage

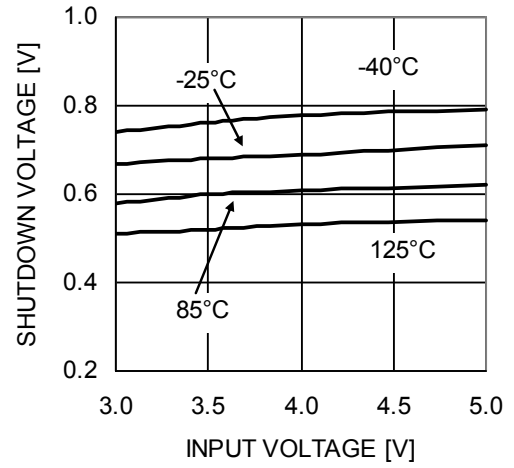

Switch Current Limit

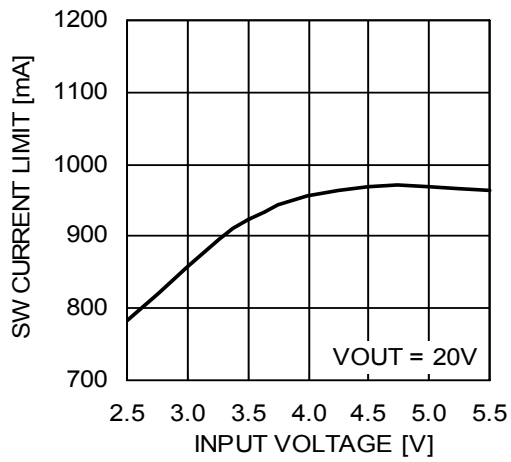

PIN DESCRIPTION

VIN is the supply input for the internal logic. The device is compatible with supply voltages down to 2.8V and up to 5.5V. It is recommended that a small bypass ceramic capacitor (4.7µF) be placed between the VIN and GND pins near the device. If the supply voltage drops below 1.9V, the device stops switching.

SHDN is the shutdown logic input. When the pin is tied to a voltage lower than 0.4V, the device is in shutdown mode, drawing nearly zero current. When the pin is connected to a voltage higher than 1.5V, the device is enabled.

GND is the ground reference pin. This pin should be connected directly to the ground plane on the PCB.

SW pin is connected to the drain of the internal CMOS power switch of the boost converter. The inductor and the Schottky diode anode should be connected to the SW pin. Traces going to the SW pin should be as short as possible with minimum loop area. An over-voltage detection circuit is connected to the SW pin. When the voltage reaches 40V, the device enters a low power operating mode preventing the SW voltage from exceeding the maximum rating.

FB feedback pin is regulated at 0.3V. A resistor connected between the FB pin and ground sets the LED current according to the formula:

$$I_{LED} = 0.3V/R1$$

The lower LED cathode is connected to the FB pin.

| Pin # | Name | Function |
|-------|------|---|
| 1 | SW | Switch pin. This is the drain of the internal power switch. |
| 2 | GND | Ground pin. Connect the pin to the ground plane. |
| 3 | FB | Feedback pin. Connect to the last LED cathode. |
| 4 | SHDN | Shutdown pin (Logic Low). Set high to enable the driver. |
| 5 | VIN | Power Supply input. |

SIMPLIFIED BLOCK DIAGRAM

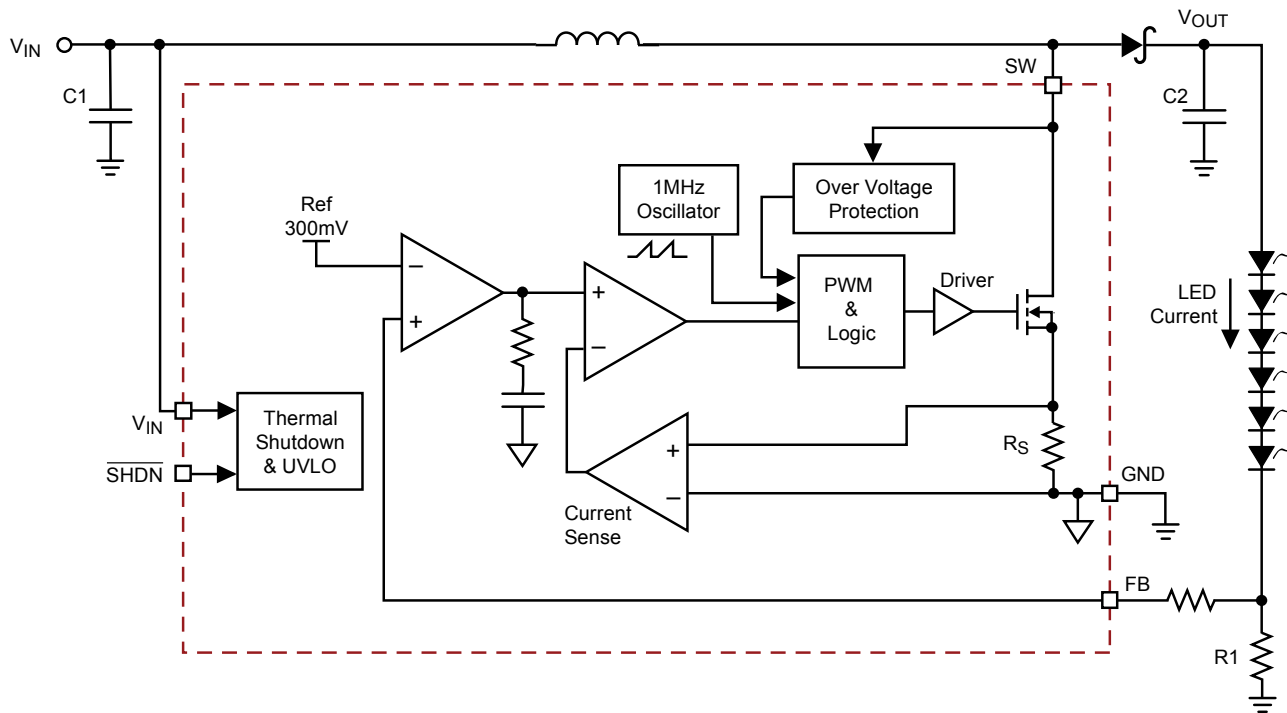

DEVICE OPERATION

The CAT4240 is a fixed frequency (1MHz), low noise, inductive boost converter that provides a constant current with excellent line and load regulation. The device uses a high-voltage CMOS power switch between the SW pin and ground to energize the inductor. When the switch is turned off, the stored energy in the inductor is released into the load via the Schottky diode.

The on/off duty cycle of the power switch is internally adjusted and controlled to maintain a constant regulated voltage of 0.3V across the feedback resistor connected to the feedback pin (FB). The value of the resistor sets the LED current accordingly ($0.3V/R1$).

During the initial power-up stage, the duty cycle of the internal power switch is limited to prevent excessive in-rush currents and thereby provide a “soft-start” mode of operation.

When the inductor is connected to a 9V supply or higher, the CAT4240 can drive 6 LEDs in series at 300mA delivering a total power of 6 Watts into the load. A separate 5V supply voltage is connected to the VIN pin.

In the event of an “Open LED” fault condition, where the feedback control loop becomes open, the output voltage will continue to increase. Once this voltage exceeds 40V, an internal protection circuit will become active and place the device into a very low power safe operating mode.

Thermal overload protection circuitry has been included to prevent the device from operating at unsafe junction temperatures above 150°C. In the event of a thermal overload condition the device will automatically shutdown and wait till the junction temperatures cools to 130°C before normal operation is resumed.

APPLICATION INFORMATION

External Component Selection

Capacitors

The CAT4240 only requires small ceramic capacitors of 4.7µF on the inductor input, 1µF on the VIN pin and 1µF on the output. Under normal condition, a 4.7µF input capacitor is sufficient. For applications with higher output power, a larger input capacitor of 10µF may be appropriate. X5R and X7R capacitor types are ideal due to their stability across temperature range.

Inductor

A 47µH inductor is recommended for most of the CAT4240 applications. In cases where the efficiency is critical, inductances with lower series resistance are preferred. Inductors with current rating of 800mA or higher are recommended for most applications. Sumida CDRH6D28-470 47µH inductor has a rated current of 800mA and a series resistance (D.C.R.) of 176mΩ typical.

Schottky Diode

The current rating of the Schottky diode must exceed the peak current flowing through it. The Schottky diode performance is rated in terms of its forward

voltage at a given current. In order to achieve the best efficiency, this forward voltage should be as low as possible. The response time is also critical since the driver is operating at 1MHz. Central Semiconductor Schottky rectifier CMSH1-40 (1A rated) is recommended for most applications.

LED Current Setting

The LED current is set by the external resistor R1 connected between the feedback pin (FB) and ground. The formula below gives the relationship between the resistor and the current:

$$R1 = 0.3V/LED \text{ current}$$

| LED current (mA) | R1 (Ω) |
|------------------|--------|
| 20 | 15 |
| 25 | 12 |
| 30 | 10 |
| 100 | 3 |
| 300 | 1 |

Table 1. Resistor R1 and LED current

OPEN LED PROTECTION

In the event of an “Open LED” fault condition, the CAT4240 will continue to boost the output voltage with maximum power until the output voltage reaches approximately 40V. Once the output exceeds this level, the internal circuitry immediately places the device into a very low power mode where the total input power is limited to about 6mW (about 1.6mA input current with a 3.6V supply). The SW pin clamps at a voltage below its maximum rating of 60V. There is no need to use an external zener diode between Vout and the FB pin. A 50V rated C2 capacitor is required to prevent any overvoltage damage in the open LED condition.

Open LED Disconnect and Reconnect

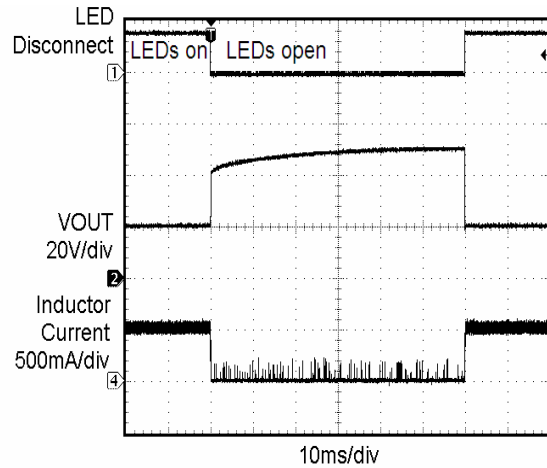

Open LED Protection without Zener

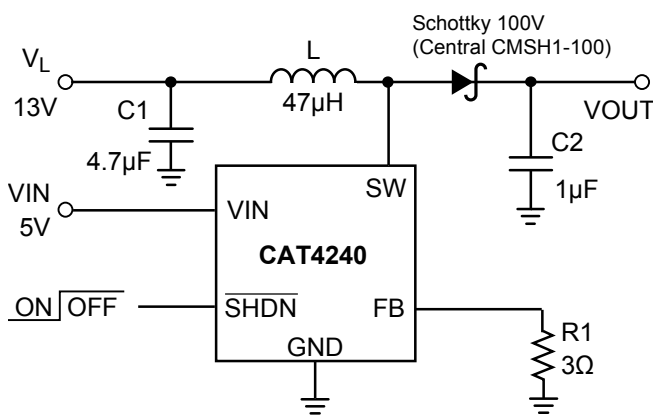

Open LED Disconnect

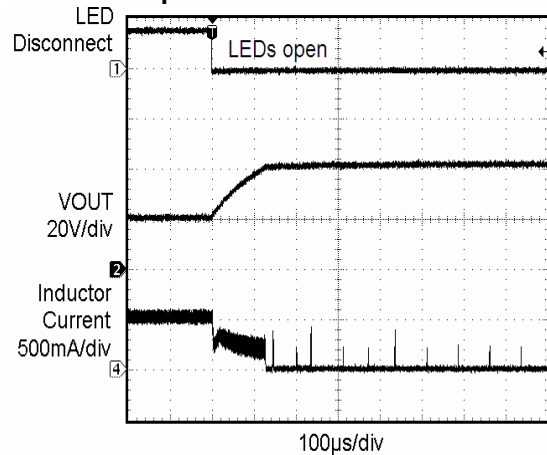

Open LED Supply Current vs. VIN without Zener

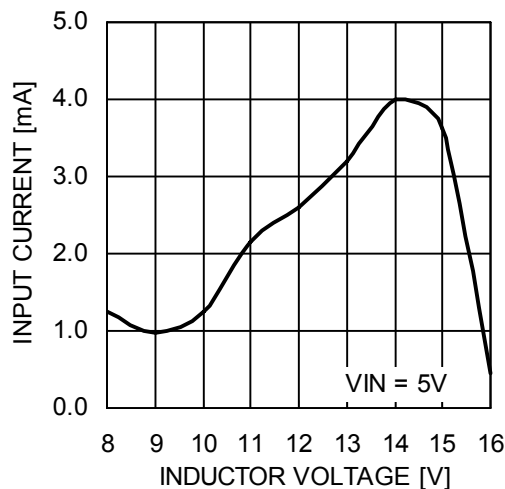

Open LED Output Voltage vs. VIN without Zener

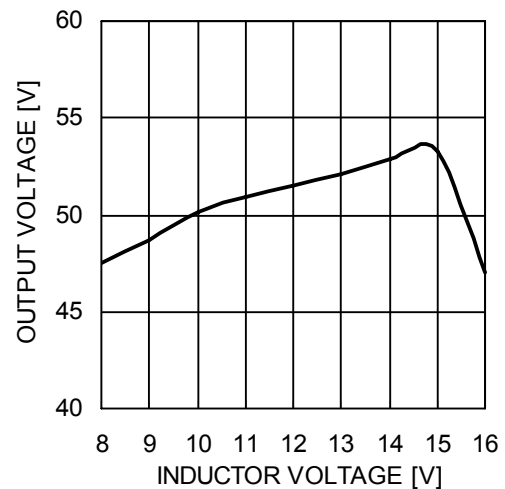

DIMMING CONTROL

There are several methods available to control the LED brightness.

PWM signal on the $\overline{\text{SHDN}}$ Pin

LED brightness dimming can be done by applying a PWM signal to the $\overline{\text{SHDN}}$ input. The LED current is repetitively turned on and off, so that the average current is proportional to the duty cycle. A 100% duty cycle, with $\overline{\text{SHDN}}$ always high, corresponds to the LEDs at nominal current. Figure 1 shows a 1kHz signal with a 50% duty cycle applied to the $\overline{\text{SHDN}}$ pin. The recommended PWM frequency range is from 100Hz to 2kHz.

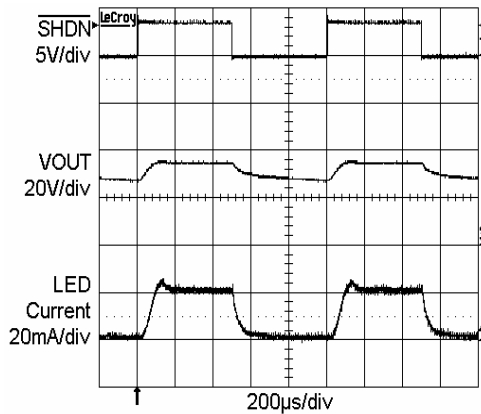

Figure 1. Switching Waveform with 1kHz PWM on $\overline{\text{SHDN}}$

Filtered PWM Signal

A filtered PWM signal used as a variable DC voltage can control the LED current. Figure 2 shows the PWM control circuitry connected to the CAT4240 FB pin. The PWM signal has a voltage swing of 0V to 2.5V. The LED current can be dimmed within a range from 0mA to 20mA. The PWM signal frequency can vary from very low frequency up to 100kHz.

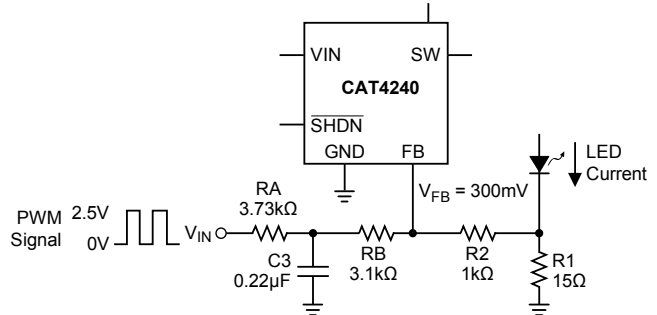

Figure 2. Circuit for Filtered PWM Signal

A PWM signal at 0V DC, or a 0% duty cycle, results in a max LED current of about 22mA. A PWM signal with a 93% duty cycle or more, results in an LED current of 0mA.

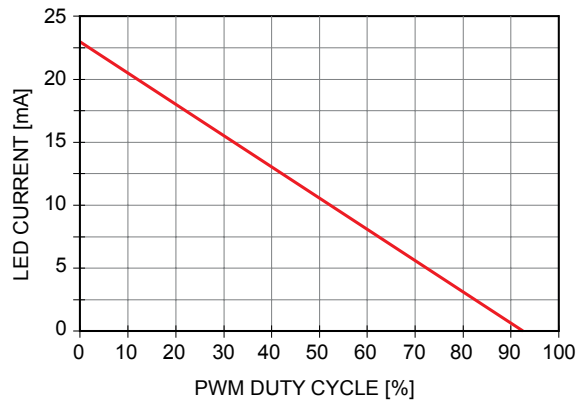

Figure 3. Filtered PWM Dimming [0V to 2.5V]

BOARD LAYOUT

The CAT4240 is a high-frequency switching regulator. The traces that carry the high-frequency switching current have to be carefully laid out on the board in order to minimize EMI, ripple and noise in general. The thicker lines on Figure 4 show the switching current path. All these traces have to be short and wide enough to minimize the parasitic inductance and resistance. The loop shown on Figure 4 corresponds to the current path when the CAT4240 internal switch is closed. On Figure 5 is shown the current loop, when the CAT4240 switch is open. Both loop areas should be as small as possible.

Capacitor C1 has to be placed as close as possible to the VIN pin and GND. The capacitor C2 has to be connected separately to the top LED anode. A ground plane under the CAT4240 allows for direct connection of the capacitors to ground. The resistor R1 must be connected directly to the GND pin of the CAT4240 and not shared with the switching current loops and any other components.

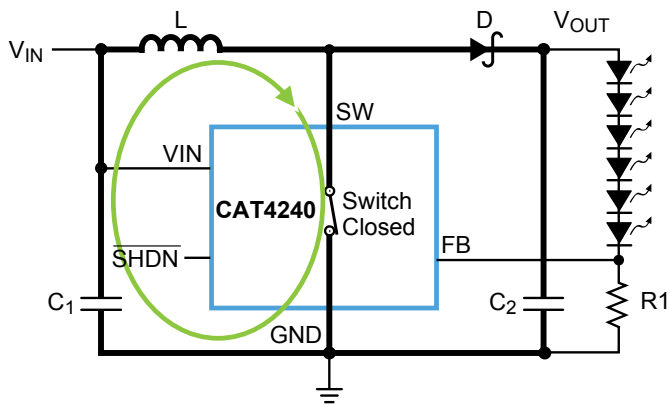

Figure 4. Closed-switch Current Loop

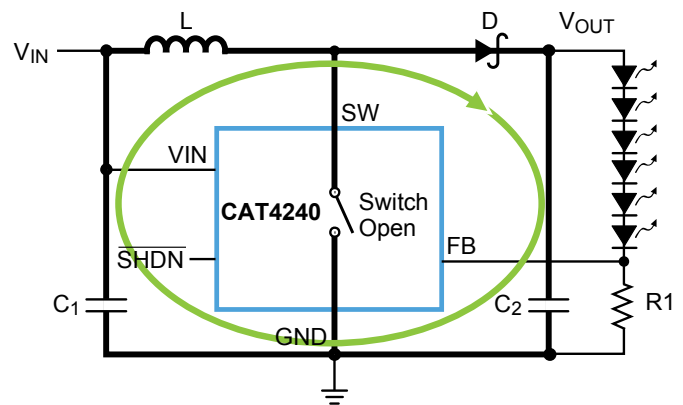

Figure 5. Open-switch Current Loop

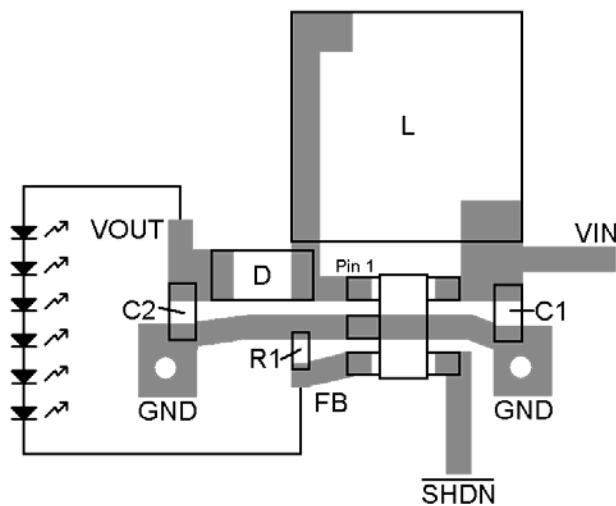
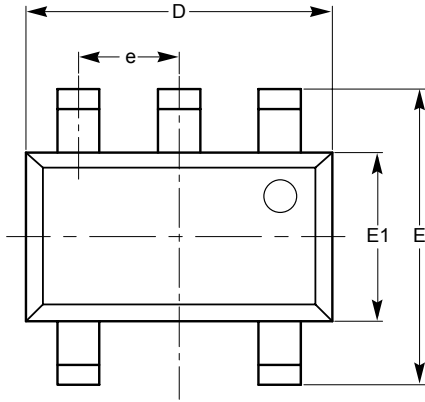

Figure 6. Recommended PCB Layout

PACKAGE OUTLINE DRAWING

TSOT-23 5-Lead (TD)⁽¹⁾⁽²⁾



TOP VIEW

| SYMBOL | MIN | NOM | MAX |
|----------|----------|------|------|
| A | | | 1.00 |
| A1 | 0.01 | 0.05 | 0.10 |
| A2 | 0.80 | 0.87 | 0.90 |
| b | 0.30 | | 0.45 |
| c | 0.12 | 0.15 | 0.20 |
| D | 2.90 BSC | | |
| E | 2.80 BSC | | |
| E1 | 1.60 BSC | | |
| e | 0.95 TYP | | |
| L | 0.30 | 0.40 | 0.50 |
| L1 | 0.60 REF | | |
| L2 | 0.25 BSC | | |
| θ | 0° | | 8° |

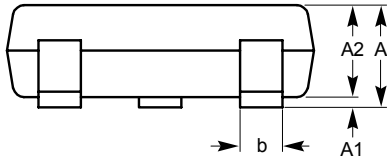

SIDE VIEW

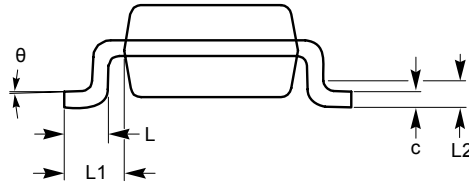

END VIEW

Notes:

- (1) All dimensions are in millimeters, angles in degrees.
- (2) Complies with JEDEC standard MO-193.

EXAMPLE OF ORDERING INFORMATION

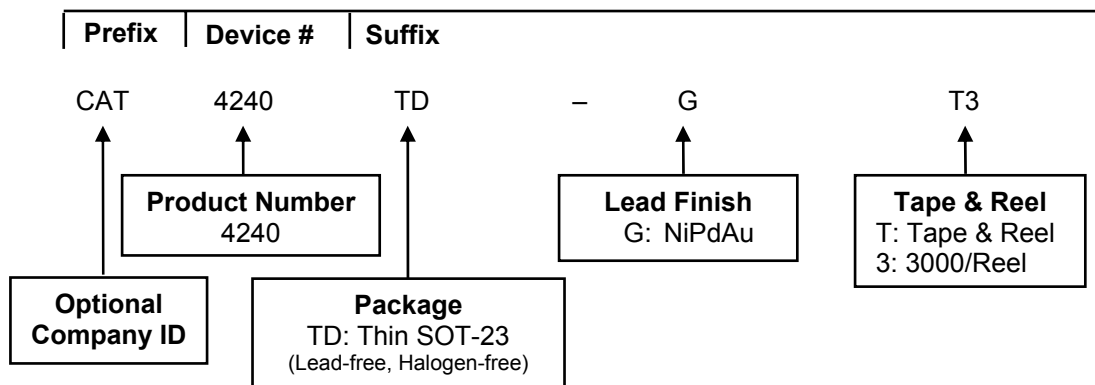

SERIES LED DRIVERS

| Part Number | Description |
|-------------|--|
| CAT4137 | CMOS Boost Converter – White LED Driver |
| CAT4237 | High Voltage CMOS Boost White LED Driver |
| CAT4238 | High Efficiency 10 LED Boost Converter |
| CAT4139 | 22V High Current Boost White LED Driver |
| CAT4240 | 6 Watt Boost LED Driver |

Notes:

- (1) All packages are RoHS-compliant (Lead-free, Halogen-free).
- (2) The standard lead finish is NiPdAu.
- (3) The device used in the above example is a CAT4240–GT3 (TSOT-23, NiPdAu, Tape & Reel).
- (4) For additional package and temperature options, please contact your nearest ON Semiconductor Sales office.
- (5) Switch current limit, typical values.

REVISION HISTORY

| Date | Rev. | Description |
|-----------|------|--|
| 31-May-07 | A | Initial Issue |
| 17-Oct-07 | B | Update Absolute Maximum Ratings Update Package Outline Drawing |
| 06-Nov-07 | C | Update Simplified Block Diagram Update Device Operation text Update Board Layout figure numbers Update Series LED Drivers table |
| 19-Nov-08 | D | Change logo and fine print to ON Semiconductor |

ON Semiconductor and  are registered trademarks of Semiconductor Components Industries, LLC (SCILLC). SCILLC reserves the right to make changes without further notice to any products herein. SCILLC makes no warranty, representation or guarantee regarding the suitability of its products for any particular purpose, nor does SCILLC assume any liability arising out of the application or use of any product or circuit, and specifically disclaims any and all liability, including without limitation special, consequential or incidental damages. "Typical" parameters which may be provided in SCILLC data sheets and/or specifications can and do vary in different applications and actual performance may vary over time. All operating parameters, including "Typicals" must be validated for each customer application by customer's technical experts. SCILLC does not convey any license under its patent rights nor the rights of others. SCILLC products are not designed, intended, or authorized for use as components in systems intended for surgical implant into the body, or other applications intended to support or sustain life, or for any other application in which the failure of the SCILLC product could create a situation where personal injury or death may occur. Should Buyer purchase or use SCILLC products for any such unintended or unauthorized application, Buyer shall indemnify and hold SCILLC and its officers, employees, subsidiaries, affiliates, and distributors harmless against all claims, costs, damages, and expenses, and reasonable attorney fees arising out of, directly or indirectly, any claim of personal injury or death associated with such unintended or unauthorized use, even if such claim alleges that SCILLC was negligent regarding the design or manufacture of the part. SCILLC is an Equal Opportunity/Affirmative Action Employer. This literature is subject to all applicable copyright laws and is not for resale in any manner.

PUBLICATION ORDERING INFORMATION

LITERATURE FULFILLMENT:

Literature Distribution Center for ON Semiconductor
P.O. Box 5163, Denver, Colorado 80217 USA
Phone: 303-675-2175 or 800-344-3860 Toll Free USA/Canada
Fax: 303-675-2176 or 800-344-3867 Toll Free USA/Canada
Email: orderlit@onsemi.com

N. American Technical Support: 800-282-9855 Toll Free
USA/Canada
Europe, Middle East and Africa Technical Support:
Phone: 421 33 790 2910
Japan Customer Focus Center:
Phone: 81-3-5773-3850

ON Semiconductor Website: www.onsemi.com
Order Literature: <http://www.onsemi.com/orderlit>
For additional information, please contact your local Sales Representative